

Technical data sheet

Product features



Electric drop-in induction cooker with 2 drop-in hotplates 400 V

Model	SAP Code	00007449
--------------	-----------------	----------



- Device type: Electric unit
- Power consumption of the zone 1 [kW]: 5
- Power consumption of the zone 2 [kW]: 5
- Protection of controls: IPX5
- Material: Stainless steel

SAP Code	00007449	Loading	400 V / 3N - 50 Hz
Net Width [mm]	400	Number of zones	2
Net Depth [mm]	600	Power consumption of the zone 1 [kW]	5
Net Height [mm]	310	Power consumption of the zone 2 [kW]	5
Net Weight [kg]	20.00	Ceramic glass dimensions [mm x mm]	350 x 570
Power electric [kW]	10.000		

Technical data sheet

Technical drawing



Electric drop-in induction cooker with 2 drop-in hotplates 400 V

Model

SAP Code

00007449



Tabella			
Descrizione	A	C	D
PCID-64ETD	400 mm	100 cm ²	150 cm ²
PCID-68ETD	800 mm	165 cm ²	200 cm ²

A	Data plate		B	Electrical connection	
---	------------	--	---	-----------------------	--

Technical data sheet

Product benefits

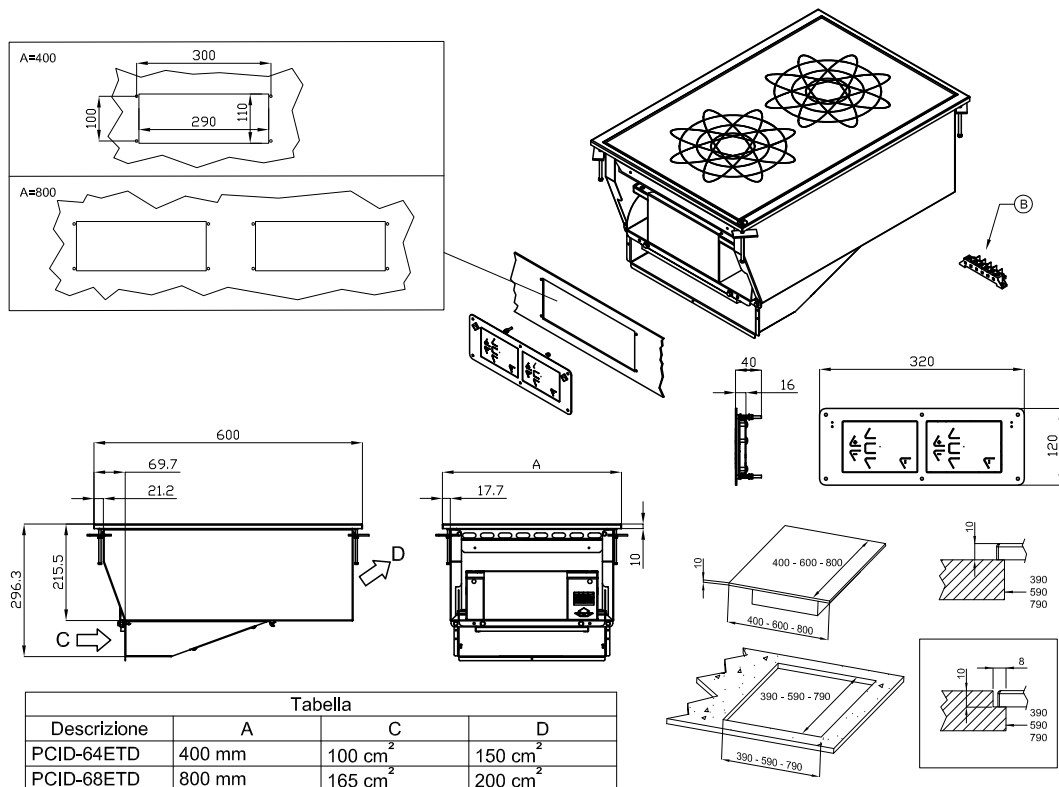

Electric drop-in induction cooker with 2 drop-in hotplates 400 V

Model	SAP Code	00007449
--------------	-----------------	----------

1

Induction surface with digital control

fastest heating of the cooking zone
precise heating only at the place where the container is placed

- time-saving for food preparation
- no reheating and long cooking times

2

Degree of protection of the control elements IPX5

maintenance-free system
resistance to splash water
long life

- savings on service interventions
- easy cleaning and maintenance of equipment

3

All-stainless design

the material does not cut
wear resistance of the material
long life

- savings on service interventions
- easy cleaning and maintenance of equipment

4

Hygienic moldings of the top plate

absence of sharp corners and edges (potential places where dirt could stick)
smooth transitions

- easy quick cleaning

5

Variability

the possibility of attaching to a fixed plate as part of a monoblock
the possibility of creating one module
long life

- cost saving
- space saving
- long service life

Technical data sheet

Technical parameters



Electric drop-in induction cooker with 2 drop-in hotplates 400 V

Model

SAP Code

00007449

1. SAP Code:

00007449

2. Net Width [mm]:

400

3. Net Depth [mm]:

600

4. Net Height [mm]:

310

5. Net Weight [kg]:

20.00

6. Gross Width [mm]:

470

7. Gross depth [mm]:

700

8. Gross Height [mm]:

530

9. Gross Weight [kg]:

25.00

10. Device type:

Electric unit

11. Construction type of device:

Drop-in

12. Power electric [kW]:

10.000

13. Loading:

400 V / 3N - 50 Hz

14. Protection of controls:

IPX5

15. Material:

Stainless steel

16. Worktop type:

Molded - comfortable cleaning maintenance

17. Worktop material:

AISI 304

18. Worktop Thickness [mm]:

2.00

19. Number of zones:

2

20. Power consumption of the zone 1 [kW]:

5

21. Power consumption of the zone 2 [kW]:

5

22. Power control type:

digital

23. Number of power control stages:

6

24. Service accessibility:

From the front by removing the front panel and waste fluid containers

25. Number of burners/hot plates:

2

26. Type of electric cooking zones:

Induction

Technical data sheet

Technical parameters



Electric drop-in induction cooker with 2 drop-in hotplates 400 V

Model	SAP Code	
		00007449

27. Ceramic glass dimensions [mm x mm]:

350 x 570

28. Cross-section of conductors CU [mm²]:

2,5

– Výkon (kW): 11-17 (230 V); 19-30 (400 V)